



the art of sound
ARTISON[®]
INSTALLATION GUIDE

LCR DualMono[®] In-Wall Kit

LCRDM-IW-KIT

CARTON CONTENTS:

- 2. In-Wall Mounting Rings
- 2. Micro Perforated Steel Grilles
- 4. LCR-DM Speaker Clamps
- 2. Portrait LCR-DM & Sketch LCR-DM Baffle Walls
- 1. Cut Out Template
- 1. Installation Guide

If you are missing any of these parts or if you need assistance during the installation of your LCR-DM In-Wall Kit, please contact Artison's Customer Service Department during normal business hours, Pacific Time at (775) 783-4770.

Thank you for choosing the Artison LCR DualMono® In-Wall Kit. We are pleased that you have selected our high-performance audio products. The following information will guide you through the installation of your Artison LCR DualMono In-Wall Kit and Speakers.

INTRODUCTION

Artison LCR DualMono® (LCR-DM) speakers are designed to be used with this kit in conjunction with any of the LCR-DM speakers.

Artison's patented DualMono Center Channel design uses an array of two Center Channels, one Left Channel, and one Right Channel; all housed in two aluminum enclosures. All 4 speakers have independent air chambers and crossovers. The In-Wall LCR-DM Kit maintains the closed-back design of the LCR-DM which ensures that the performance of the speaker is maintained, independent of the wall cavity size or wall construction type. The two adapted enclosures are then fitted into the in-wall mounting rings, hidden inside the wall and covered with ultra-low profile micro-perforated grilles. This creates less visual clutter by eliminating the above or below standard center channel speaker, thus enabling one TOTAL INVOLVEMENT EXPERIENCE®.

INSTALLING THE IN-WALL LCR SPEAKERS

This section will give you installation tips and instructions on how to install and run speaker wire for your Artison In-Wall LCR-DM.

SPEAKER PLACEMENT GUIDELINES

1. The In-Wall LCRs were designed to complement a Flat Panel Display by being installed in the wall on the Left and Right sides of the display.
2. The In-Wall LCRs were designed to be compatible with a standard 2 x 4 stud wall.
 - 2.1. Cut out Dimensions are:
31.1 in. x 7.6 in (790 mm x 193 mm)
The minimum mounting depth for the In-Wall LCRs is 2.9" (74 mm). The Dog Clamps were designed to work with ½" or ⅝" thick drywall.
3. The In-Wall LCR enclosures should both be:
 - 3.1. Installed at the same height in the wall.
 - 3.2. Installed no more that 10 ft apart horizontally.
 - 3.3. Installed equal distances away from the flat panel display.
 - 3.4. Installed with the DualMono Center Channels being the upper speaker. This is indicated by left and right marked on the front of the speaker.

When painting the LCR-DM In-Wall Kit, please remove the grille and trim ring assembly from the speaker and paint separately. The fabric scrim coating should be gently removed from the grille before painting and replaced after drying is complete. **DO NOT get paint on the speaker baffle or drive units. Paint can damage the components which would VOID your Warranty.**

ATTACHING THE IN-WALL KIT

1. Remove the metal bands from the rear of the baffle frame with a #2 philips screwdriver. If using the M-LCR-DM also remove the additional baffle wall with the same tool.
2. Insert the LCR-DM Speaker from the back of the baffle frame into the opening until it sits flat into the frame.
3. Place the 2 metal bands per speaker around the aluminum extrusion of the LCR-DM and tighten the 4 screws in place to secure the speaker.

SPECIFICATIONS & DIMENSIONS:

LCR DUALMONO® IN-WALL KIT

LCR-DM-IW-KIT

Dimensions:	32.8" x 9.2" x 3", HWD Overall 7.6" x 31.1", HW Cut Out Dimensions
Cabinet / Finish:	Glass Filled ABS / Black Satin; Micro Perforated Steel Grille / White Powdercoat , Can be Painted
System Weight:	5 lbs. (2.5 kg.) including Mounting Hardware & Grilles

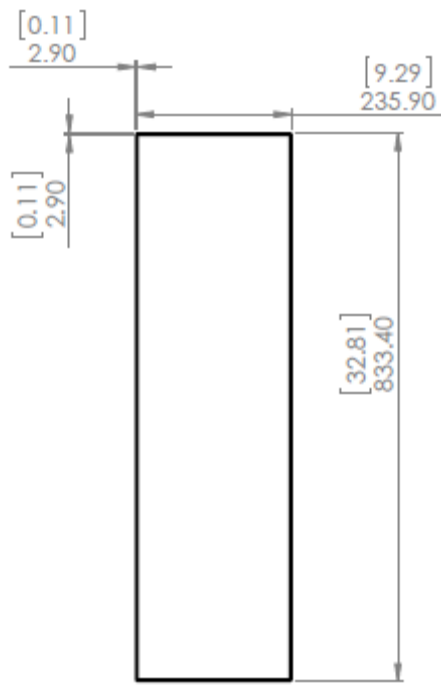

Cut Out Dimensions: 7.6" W x 31.1" H
Mounting Flange Width: 0.5"
Finished Height above Drywall: 0.1"
Bezel Width: 0.1"

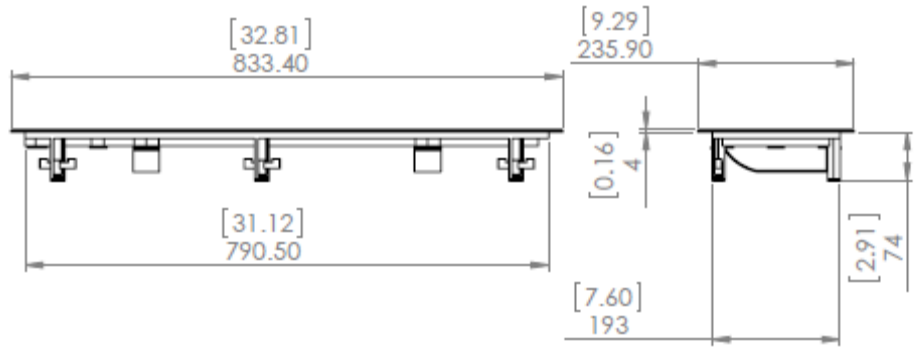

LIMITED WARRANTY

This warranty remains in effect for five years from the date of purchase for speaker products and one year for electronic products.

THIS WARRANTY PROTECTS THE ORIGINAL OWNER PROVIDING THAT THE PRODUCT HAS BEEN PURCHASED FROM AN AUTHORIZED ARTISON DEALER IN THE UNITED STATES. THE ORIGINAL BILL OF SALE MUST BE PRESENTED WHENEVER WARRANTY SERVICE IS REQUIRED. FOR WARRANTY SERVICE OUTSIDE THE UNITED STATES, CONTACT THE AUTHORIZED ARTISON DISTRIBUTOR IN THE COUNTRY WHERE THE PRODUCT WAS PURCHASED.

Except as specified below, this warranty covers all defects in material and workmanship. The following are not covered: Damage caused by accident, misuse, abuse, product modification or neglect, damage occurring during shipment, damage from failure to follow instructions contained in the Owners Manual, damage resulting from the performance of repairs by someone not authorized by Artison, or any claims based on misrepresentations by the seller. This warranty does not cover incidental or consequential damages. It does not cover the cost of removing or reinstalling the unit. **THIS WARRANTY IS VOID IF THE SERIAL NUMBER HAS BEEN REMOVED OR DEFACED, OR IS PURCHASED FROM AN UNAUTHORIZED DEALER ON THE INTERNET (WORLD WIDE WEB), MAIL ORDER, 800, 888, 877 TELEPHONE NUMBERS OR THROUGH A CATALOG.**

This warranty gives you specific legal rights. You may also have other rights, which vary from state to state. Some states do not allow the exclusion or limitation of incidental or consequential damages or limitations on how long an implied warranty lasts, so the above may not apply to you.

Please make note of the following information and retain for your record.

Product Name _____ Model Number _____

Store Name _____ Purchase Price _____

HOW TO OBTAIN SERVICE

Please call us at (775) 783-4770, or write to: ARTISON (Attention: Customer Service Department), 2231 Meridian Blvd, Suite 1, Minden, NV 89423.

We will promptly advise you of what action to take. We may direct you to an authorized Artison Service Center or ask you to send your speaker to the factory for repair. You will need to present the original bill of sale to establish the date of purchase. **PLEASE DO NOT SHIP YOUR ARTISON PRODUCT TO THE FACTORY FOR REPAIR WITHOUT PRIOR AUTHORIZATION. PLEASE DO NOT RETURN PRODUCT TO THE ABOVE ADDRESS, IT IS NOT A SERVICE LOCATION.** You are responsible for transporting your product for repair and for payment of any initial shipping charges. However, we will pay the return shipping charges if the repairs are covered under warranty.